



Development of Liquid Fertilizer Applicator

PREM K SUNDARAM^{1*} AND INDRA MANI²

¹Division of Land & Water Management, ICAR-Research Complex for Eastern Region, Patna, Bihar 800014, India

²Division of Agricultural Engineering, ICAR-Indian Agricultural Research Institute, New Delhi 110012, India

ABSTRACT

A liquid fertilizer applicator was developed which could place liquid fertilizer inside soil simultaneously with seed. The metering system was calibrated for nitrogen basal dose application. There was approximately 30-33 % increase in flow rate with an increase in pressure from 0 to 1 kg-cm⁻² whereas there was only 6-10 % increase in flow rates when pressure changed from 1 to 2 kg-cm⁻². A shovel type furrow opener was modified to conduit the fertilizer into the soil. Modified shovel furrow openers were able to place liquid fertilizer inside the soil at a depth of 3-4 cm below the wheat seed. The average field capacity of 0.23 hah-1 was obtained for continuous operation of the applicator at an average speed of 1.78 kmh-1. A field efficiency of 72 % was observed which was in the permissible range of 60-80 % for seed drill.

KEYWORDS : applicator, tractor, liquid fertilizer, calibration, prototype



ARTICLE INFO

Received on	: 05.07.2018
Accepted on	: 21.09.2018
Published online	: 15.12.2018

INTRODUCTION

The most widely used nitrogen-based liquid fertilizer in these countries is Urea Ammonium Nitrate (UAN) which is an aqueous solution of urea and ammonium nitrate. UAN solutions are commonly injected into the soil beneath the surface, sprayed onto the soil surface, dribbled as a band onto the surface, added to irrigation water, or sprayed onto plant leaves as a source of foliar nutrition (IPNI 2019).

In India, 84% of the total fertilizer consumption is in the form of prilled urea. In India, way back in the 1970s, a public sector company developed a liquid fertilizer 'Ankur' which was found to be a good source of Nitrogen for wheat (Singh and Aggrawal 2012). In spite of a number of benefits of liquid fertilizers for manufacturers' as well for farmers, the use of liquid fertilizers did not pick up in India due to lack of appropriate liquid fertilizer application technology. The non-availability of scientific data on application methodology and yield benefits of UAN and the lack of necessary proper storage and transport facilities for UAN among farmers hindered the popularization of liquid fertilizer (UAN) in the country.

Application of liquid fertilizer alongside the seed needs a precise and proper method to avoid contact of seed with liquid fertilizer. The precise placement of fertilizer and seed is critical for the efficient use of fertilizer and for enhanced plant growth. Simultaneous placement of seed and liquid fertilizer requires the development of a liquid fertilizer application system that can facilitate the differential depth application of seed and liquid fertilizer for proper seed emergence and root establishment.

Keeping the above points in view, a tractor-drawn liquid fertilizer applicator prototype which could place the fertilizer inside soil was designed and developed.

MATERIALS AND METHODS

For the development of liquid fertilizer (UAN) application system, optimum placement depth of liquid fertilizer in the soil, furrow opener design and appropriate liquid fertilizer metering system are of critical importance. It was recommended to keep a vertical gap of at least 2 and 3 cm between seed and UAN with dilution ratio (UAN: Water) of 1:10 and 1:5 respectively while sowing wheat (Sundaram *et al.*, 2017). For the design of furrow opener, type, size and material need to be given due consideration. In contrast to granular fertilizer, the liquid fertilizer metering can be either gravity fed or pressurized. The pressurized metering system although better in performance as compared to gravity fed, demands an optimum operating pressure and efficient liquid distribution system. Urea Ammonium Nitrate fertilizer was provided by the National Fertilizer Limited, Nangal, India.

Design of various components of liquid fertilizer applicator

Different components of liquid fertilizer applicator viz. furrow opener, liquid fertilizer metering system, power transmission system for the pump, seed hopper and liquid fertilizer tank were designed and fabricated.

Furrow opener

Furrow opener was the most critical component in the design of liquid fertilizer applicator as it had to make a furrow as well as help in placing liquid fertilizer below the seed. Shovel type

*Corresponding author email: prem.k.sundaram@gmail.com

furrow openers were selected as they are the most common type of furrow openers used in conventional tillage (Chaudhuri 2001). Due to the corrosiveness of UAN liquid fertilizer towards mild steel (Cahoon 2002), it was decided to use narrow Poly Vinyl Chloride (PVC) tubes for the conduit of liquid fertilizer in order to avoid contact between UAN and the furrow opener surface. A groove of cross-section 7x 7 mm was made in the lower front shank to fit the selected delivery pipe for liquid fertilizer. For placement of seed, the boot of the conventional seed drill was modified by split opening the lower part into two halves and shaping it with the help of hammer in the form of small furrow opener.

Liquid fertilizer metering system

To avoid over-fertilization and under fertilization, liquid fertilizer should be distributed uniformly among different delivery tubes for uniform on field application. A circular distributor made of nylon was designed and developed. It had a simple design with a central inlet opening into a disc-shaped chamber. To maintain uniform pressure and uniformity of flow, the volume of the inside chamber of the distributor was kept as minimum as possible. Nine holes were drilled around the periphery of the distributor at a spacing of 10 mm and each hole was screwed. The discharge from each pipe was measured and used for the analysis of flow uniformity and calibration.

Fabrication of UAN applicator

Based on the selected designed values of different components of UAN applicator, a prototype was fabricated. The complete machine with various components is shown in Fig. 1 and 2.

Field evaluation of developed UAN applicator

The field experiments for the performance evaluation of the tractor operated UAN applicator designed and developed after laboratory testing, was carried out in the experimental farm of IARI, New Delhi.

Field Capacity and Field Efficiency

The theoretical field capacity is the rate of field coverage that would be obtained if the applicator was operating continuously without interruptions like turning at the ends and filling of the hopper. The effective field capacity is the actual average rate of coverage including the time lost in filling hopper and turning at the end of rows (Kepner *et al.*, 1987).

$$\text{Theoretical field capacity} = \frac{WXS}{10}, \text{ hah}^{-1}$$

Where,

W= width of coverage, m

S= Speed of operation, kmh⁻¹

Field efficiency is the ratio of effective field capacity to the theoretical field capacity as shown below¹².

$$E_f = \frac{FC_e}{FC_t} \times 100$$

Where,

E_f : Field efficiency, per cent

FC_e : Effective field capacity, hah⁻¹

FC_t : Theoretical field capacity, hah⁻¹

RESULTS AND DISCUSSION

Calibration of fertilizer metering unit of the applicator

The flow rate of the pump had to commensurate with the liquid fertilizer requirement in the field. The liquid fertilizer requirement for different basal doses of N application was ascertained. The required UAN flow rate in totality as well as for individual delivery pipe at 100% basal dose of N was determined through the experimental setup. At a tractor forward speed of 1.23, 1.5 and 2 km/h, the required flow rate for 100 % basal dose of Nitrogen (@ 120 kg/ha) was 11.1, 13.5 and 17.96 l min⁻¹, respectively. The pump was operated by the motor at different speeds controlled through a variable frequency drive (VFD).

Fabrication of Prototype UAN applicator

The prototype UAN applicator was fabricated with the design values obtained during the experiment. The specification of the developed UAN applicator is described in Table 1.

Table 1: Specifications of prototype UAN applicator

Sl.No.	Items	Values
A	Over all dimensions (L X B X H), mm	1800x 1420 x 1080
B	Seed metering	
I	Type of seed metering mechanism	Fluted roller
II	Hopper size, mm	1700 x 260 x260
C	Liquid metering	
I	PVC Tank (L X B X H), mm	1040 x 620 x 465
II	Pump (Piston)	34 l min ⁻¹ @950 rpm
III	Pressure relief valve	1-7 bar
	Rotary distributor	
	Inside chamber diameter, mm	52
IV	Outer Diameter, mm	67
	No. of holes at periphery	9
	Hole dia. at periphery, mm	10
	Delivery pipes diameter (inner), mm	4
C	Ground wheel	
I	Type	Spike toothed wheel
II	Effective diameter of ground wheel, mm	360
III	Number of spikes	12
	Spike (Length x Height x Thickness)	100 x 25.5x 5
D	Furrow opener	
I	Number of furrow openers	9
II	Type of furrow opener	Shovel type
III	Groove size (fertilizer tube), mm	7 X7
F	Power transmission	
	Pulley diameter (PTO shaft), mm	152.40
	Pulley diameter (Pump), mm	63.50
G	Weight of UAN applicator	
	Tank full of UAN, kg	565
	Empty tank, kg	265

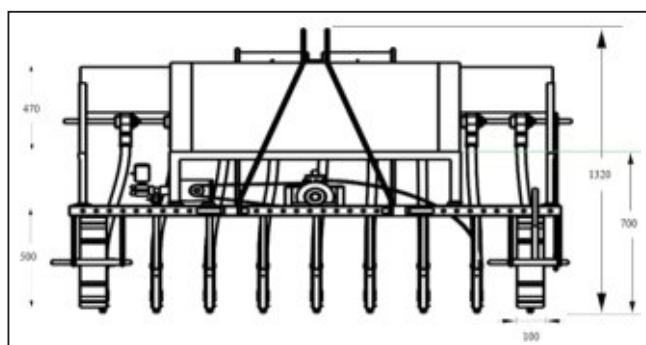

Fig. 1 Schematic diagram of liquid fertilizer applicator



Fig. 2 Developed Liquid Fertilizer applicator

Performance parameter of prototype liquid fertilizer applicator

The machine performance of liquid fertilizer applicator was studied by determining field capacity and field efficiency. The

REFERENCES

- Cahoon JR. 2002. Corrosion characteristics of mild steel in urea ammonium nitrate fertilizer solution. *Corrosion* 58(2): 166-174.
- Chaudhuri D. 2001. Performance evaluation of various types of furrow openers on seed drills: A Review. *J. Agric. Engg. Res* 79 (2):125-137.
- IPNI. 2019. Nutrient Source Specifics, No. 7, International Plant Nutrition Institute (IPNI) <http://www.ipni.net/specifics-en> (Accessed on 10th July 2019).
- Kepner RA, bainer R and Barger EL. 1987. Principles of farm machin-

ery, CBS publishers & distributors Pvt. Ltd. New Delhi, 3rd edn.

Singh NT and Aggarwal GC. 2012. Studies on simultaneous nutri-ent and water movement in soils in relation to water and fertilizer use efficiency. Final Report of I.C.A.R. ad-hoc research scheme. PAU, Ludhiana, pp:3279(2):125-137.

IPNI. 2019. Nutrient Source Specifics, No. 7, International Plant Nutrition Institute (IPNI) <http://www.ipni.net/specifics-en> (Accessed on 10th July 2019).

Kepner RA, bainer R and Barger EL. 1987. Principles of farm machin-ery, CBS publishers & distributors Pvt. Ltd. New Delhi, 3rd edn.

CONCLUSION

The prototype UAN applicator was developed with the provision to simultaneously place seed as well as liquid fertilizer. The machine consisted of three subunits- fertilizer metering system, furrow openers, and seeding unit. The fertilizer metering system included piston pump, control valve, liquid fertilizer distributor unit and delivery pipes. The pump was operated by the power take-off a unit of the tractor. The required flow rate of pump suitable for applying 100 % basal dose application of nitrogen was in the range of 11.1-17.96 lmin⁻¹ attained at a pump rotational speed of 245 to 421 revolutions per minute. The applicator was able to simultaneously place both liquid fertilizer as well as seed at desired differential depth.

ACKNOWLEDGMENTS

The authors acknowledge the support of National Fertilizer Limited, India for providing liquid fertilizer (UAN) as well as fund for the research work.

Citation:

Sundaram PK and Mani I. 2018. Development of Liquid Fertilizer Applicator. *Journal of AgriSearch* 5(4): 291-293